

SERIES: base Foundation Tensioners

IN STOCK FOR
QUICK DELIVERY



EXTENDED STUD PROTRUSION

HOLLOW BORE CYLINDER TYPE
DESIGN

base series tensioners are designed to meet specific requirements for tightening foundation bolts. They are versatile and reliable hydraulic bolt tensioners suitable for high load, tight space applications, and for **variable and extended stud protrusions** often relevant to wind turbine foundation bolt applications.

Optimised for use on **wind turbines** they have been designed for long-life, low-maintenance use, and are suitable for use on single bolts, or grouped together for multiple tightening of bolted joints.

base tensioners are extensively used for crane slewing rings, and foundation bolting on many types of civil construction projects such as bridge

STANDARD DESIGNS AVAILABLE FOR

- GE
- Siemens
- Vestas
- Gamesa
- Nordex
- Suzlon....and more!

LATEST TECHNOLOGY

- Latest seal technology
- High cycle life
- Optimised load to weight ratio
- Integrated system with TensionPro pumps and hoses

SAFE AND RELIABLE

- CE marked
- Over-stroke protection
- Max stroke indicator
- Pressure Test Certification
- Full colour operating and safety manual

OPTIONS AND FEATURES

- Special threads
- Special load requirements
- Twin or single port
- Protective handle
- Special bridge for tight clearance
- Gear drive nut run-down
- Spring piston return
- Misalignment compensation
- ARMOURMAX anti-corrosion, anti-wear

VARIABLE STUD PROTRUSION
TYPE DESIGN

OPTIONAL SAFETY HANDLE
OPTIONAL CYCLE COUNTER

THREAD OPTIONS
STANDARD METRIC
STANDARD IMPERIAL
WILLIAMS
DYSON
MACALLOY
SPECIAL THREADS

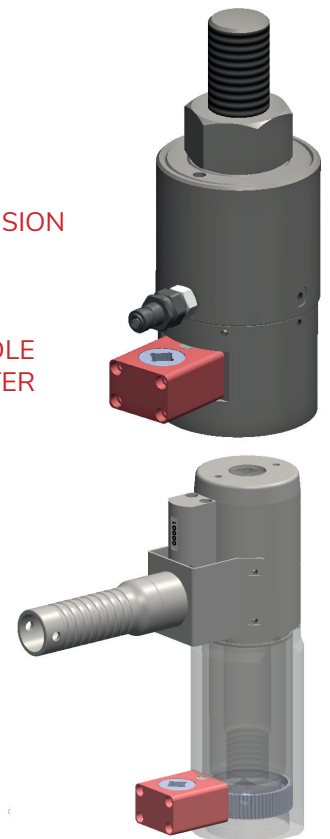

PROCESS IMPROVEMENT

base hydraulic tensioners are designed for **speed**. Fast spring piston retract, geared nut run-down and spring located sockets, improve process time on each tensioning operation.